

# ST19 LED Color Tunable Wi-Fi Bulb



Update your home's lighting with the CLEANLIFE® LED ST19 Color Tunable Bulb. Simply connect the fixture to Wi-Fi and use the CLEANLIFE® Smart App and/or your personal voice assistant to easily control features such as brightness, color temperature and on/off scheduling. Our Color Tunable Bulbs are also hub free! Unlike competitor models, there is no need to connect to a hub making this the ultimate solution in smart home lighting.



3-Year Limited Warranty

\* Dimmable via CLEANLIFE® Smart, Alexa, Google Home, and other approved apps and/or voice assistants. Do not attempt to use with standard dimmers.

## FEATURES

- 4.5W LED
- 120V AC (North America Only)
- E26 Lamp Base, Fits Most Lamp Sockets
- 2200K - 3000K Adjustable Color Temperature
- 104 Lumens Per Watt
- Wi-Fi Enabled, No Hub Required!
- Customizable Lighting Controls with the CLEANLIFE® Smart App, Google Assistant or Amazon Alexa
- CRI >80, High Color Rendering
- Rated Lifetime >15,000 Hours
- UL-Listed, FCC Compliant
- 3-Year Limited Warranty

## Color Temperature



2200K—3000K  
color tunable

## APPLICATION INFORMATION

### Applications

- Indoor
- General Lighting
- Ceiling Fixtures
- Table Lamps
- Floor Lamps

### Market Segments

- Residential

## CUSTOMIZABLE FEATURES

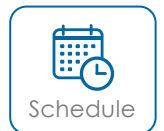

Customize and control lighting options with the CLEANLIFE® Smart App!



Wireless



Hub Free



Energy Saving



## Specifications & Data



Project/Job	Notes
Date	
Comments	
Prepared by	

### Ordering Information

Part Number	Lamp Base	Color Temperature	Rated Life (hrs.)	Input Voltage (V)	Rated Power (W) (±10%)	Nominal Lumens Per Watt	CRI (±5)
CL-SMRT-ST19-5W-2230	E26	2200K—3000K	>15,000	120V DC	4.5	104	85

### Dimensions

Part Number	Dimensions (DxH) (IN)
CL-SMRT-ST19-5W-2230	2.28 x 4.92

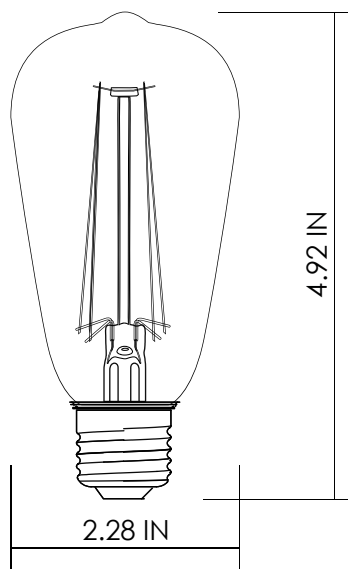

### CLEANLIFE® LED

1-800-316-2532

support@cleanlifeled.com

www.cleanlifeled.com

CLEANLIFE® and the Pinwheel Mark are registered trademarks of Superior Ventures LLC. All Rights Reserved. Not to be reproduced or published without prior permission.

PLEASE NOTE: Product specifications are based off of third party test reports and are subject to change without notice.

**CLEANLIFE®**  
SMART